

# Pearl

## 6PWS

6PWS150G Curvas de Rendimiento

DESCARGA  
3" or 4"

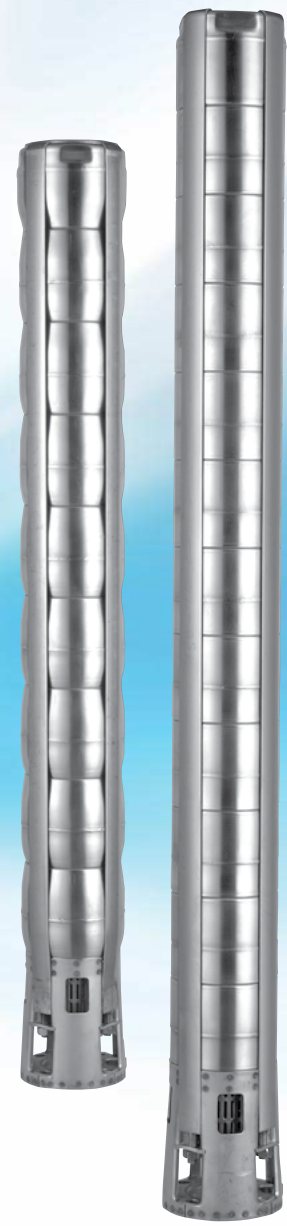
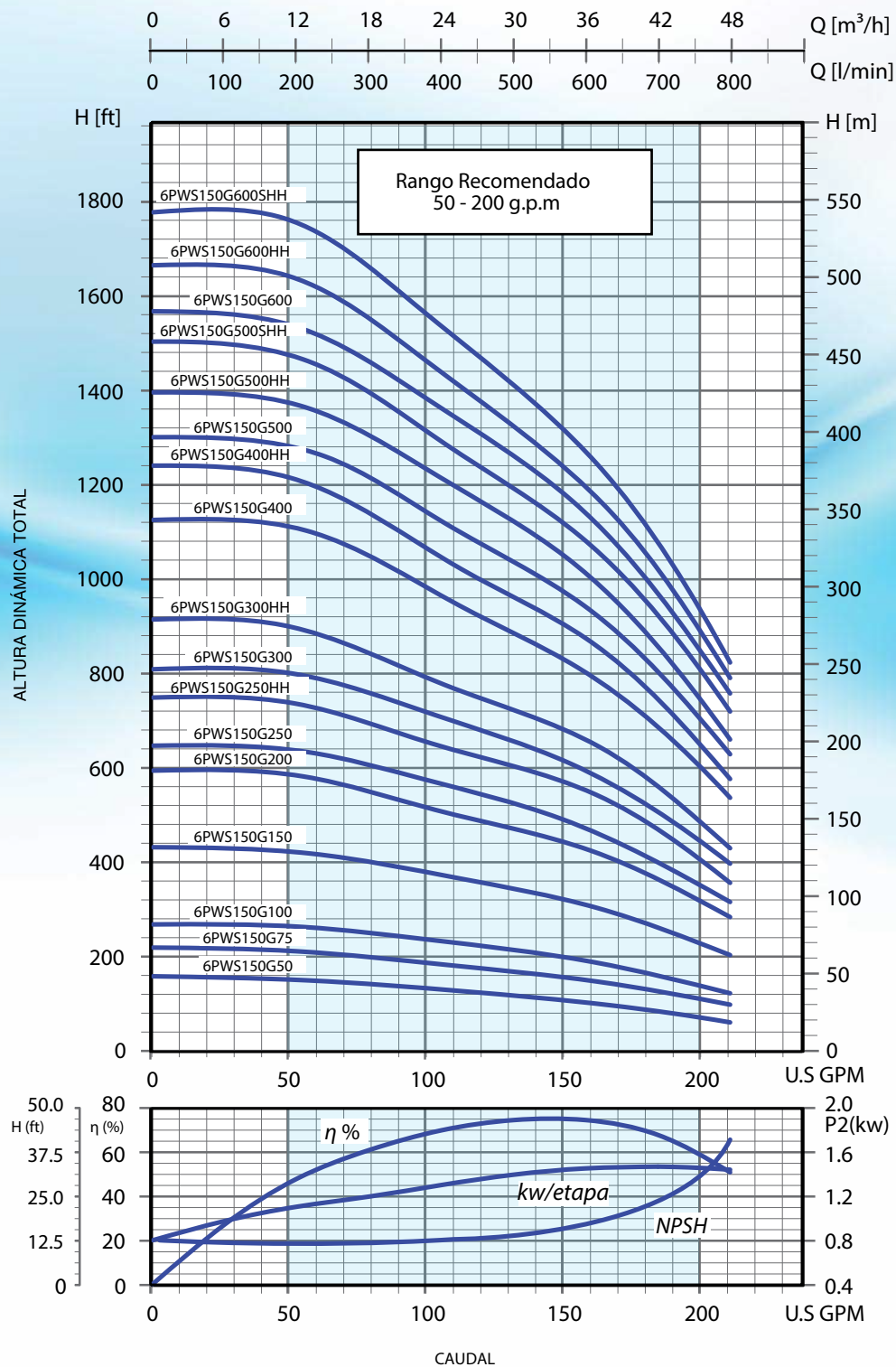

# Serie 150 gpm

Tabla de Selección - 6PWS150G

MODELO	ETAPAS	MOTOR		Q = CAUDAL																																	
				l/min 0				94.5				189				283.5				378				472.5				567				661.5				756	
		gpm 0				25				50				75				100				125				150				175				200			
		KW	HP	H = ALTURA TOTAL EN METROS / ALTURA TOTAL EN PIES																																	
M	FT			M	FT	M	FT	M	FT	M	FT	M	FT	M	FT	M	FT	M	FT	M	FT	M	FT														
6PWS150G50	3	3.7	5	49	160	49	160	47	155	47	155	40	130	37	120	34	110	26	85	23	75																
6PWS150G75	4	5	7.5	67	220	64	210	63	205	61	200	59	195	56	185	55	180	46	150	34	110																
6PWS150G100	5	7.5	10	82	270	83	272	82	268	78	255	73	240	67	220	61	200	52	170	39	128																
6PWS150G150	8	11	15	133	435	131	430	128	420	122	400	55	180	108	355	98	320	85	280	70	230																
6PWS150G200	11	15	20	183	600	181	595	180	590	169	555	159	520	146	480	134	440	119	390	98	320																
6PWS150G250	12	18.5	25	197	645	195	640	194	635	184	605	157	515	160	525	147	483	128	420	110	360																
6PWS150G250H	14	18.5	25	230	755	229	750	227	745	216	710	198	650	186	610	172	565	152	500	122	400																
6PWS150G300	15	22	30	247	810	245	805	244	800	232	762	220	720	204	670	188	615	162	530	136	445																
6PWS150G300HH	17	22	30	279	915	277	910	274	900	259	850	243	798	223	730	207	680	183	600	146	480																
6PWS150G400	21	30	40	341	1120	340	1115	338	1110	320	1050	299	980	274	900	253	830	221	725	183	600																
6PWS150G400HH	23	30	40	378	1240	377	1235	372	1220	351	1150	323	1060	299	980	274	900	242	795	197	645																
6PWS150G500	24	37	50	396	1300	395	1295	393	1290	377	1235	352	1155	323	1060	294	965	262	860	213	700																
6PWS150G500HH	26	37	50	427	1400	425	1395	424	1390	402	1320	378	1240	352	1155	319	1045	280	920	230	755																
6PWS150G500SHH	28	37	50	457	1500	456	1495	454	1490	430	1410	369	1210	300	985	341	1120	303	995	245	805																
6PWS150G600	29	45	60	476	1560	473	1550	457	1500	448	1470	421	1380	392	1285	364	1195	311	1020	244	800																
6PWS150G600HH	31	45	60	506	1660	503	1650	500	1640	476	1560	442	1450	415	1360	378	1240	335	1100	271	890																
6PWS150G600SHH	33	45	60	543	1780	540	1770	537	1760	512	1680	476	1560	439	1440	402	1320	352	1155	282	925																

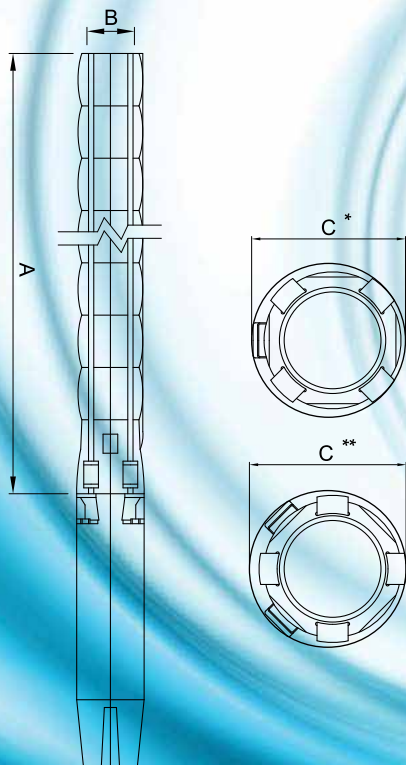

Dimensiones - 6PWS150G

MODELO	DIMENSIONES IN / MM						PESO NETO		
	A		B	C*		C**			
	IN	MM	IN	IN	MM	IN	MM	LBS	KG
6PWS150G50	21.97	558	NPT 3" or 4"	5.16	131			22.32	10.1
6PWS150G75	25.75	654	NPT 3" or 4"	5.16	131			26.08	11.8
6PWS150G100	29.53	750	NPT 3" or 4"	5.59	142	5.59	142	29.84	13.5
6PWS150G150	40.87	1038	NPT 3" or 4"	5.59	142	5.59	142	41.11	18.6
6PWS150G200	52.20	1326	NPT 3" or 4"	5.59	142	5.59	142	52.16	23.6
6PWS150G250	55.98	1422	NPT 3" or 4"	5.59	142	5.59	142	55.91	25.3
6PWS150G250H	59.76	1518	NPT 3" or 4"	5.59	142	5.59	142	63.43	28.7
6PWS150G300	67.32	1710	NPT 3" or 4"	5.59	142	5.59	142	67.18	30.4
6PWS150G300HH	74.88	1902	NPT 3" or 4"	5.59	142	5.59	142	74.70	33.8
6PWS150G400	90.00	2286	NPT 3" or 4"	5.59	142	5.59	142	89.73	40.6
6PWS150G400HH	97.56	2478	NPT 3" or 4"	5.59	142	5.59	142	97.24	44
6PWS150G500	101.34	2574	NPT 3" or 4"	5.59	142	5.59	142	100.78	45.6
6PWS150G500HH	108.90	2766	NPT 3" or 4"	5.59	142	5.59	142	108.29	49
6PWS150G500SHH	116.46	2958	NPT 3" or 4"	5.59	142	5.59	142	115.80	52.4
6PWS150G600	120.24	3054	NPT 3" or 4"	5.59	142	5.59	142	119.56	54.1
6PWS150G600HH	127.80	3246	NPT 3" or 4"	5.59	142	5.59	142	127.08	57.5
6PWS150G600SHH	135.35	3438	NPT 3" or 4"	5.59	142	5.59	142	134.59	60.9

C\* : Diámetro máximo de la bomba cuando es ensamblada con un cable de alimentación  
 C\*\* : Diámetro máximo de la bomba cuando es ensamblada con dos cables de alimentación