

# Pearl

## 6PWS

Curvas de Rendimiento - 6PWS90G

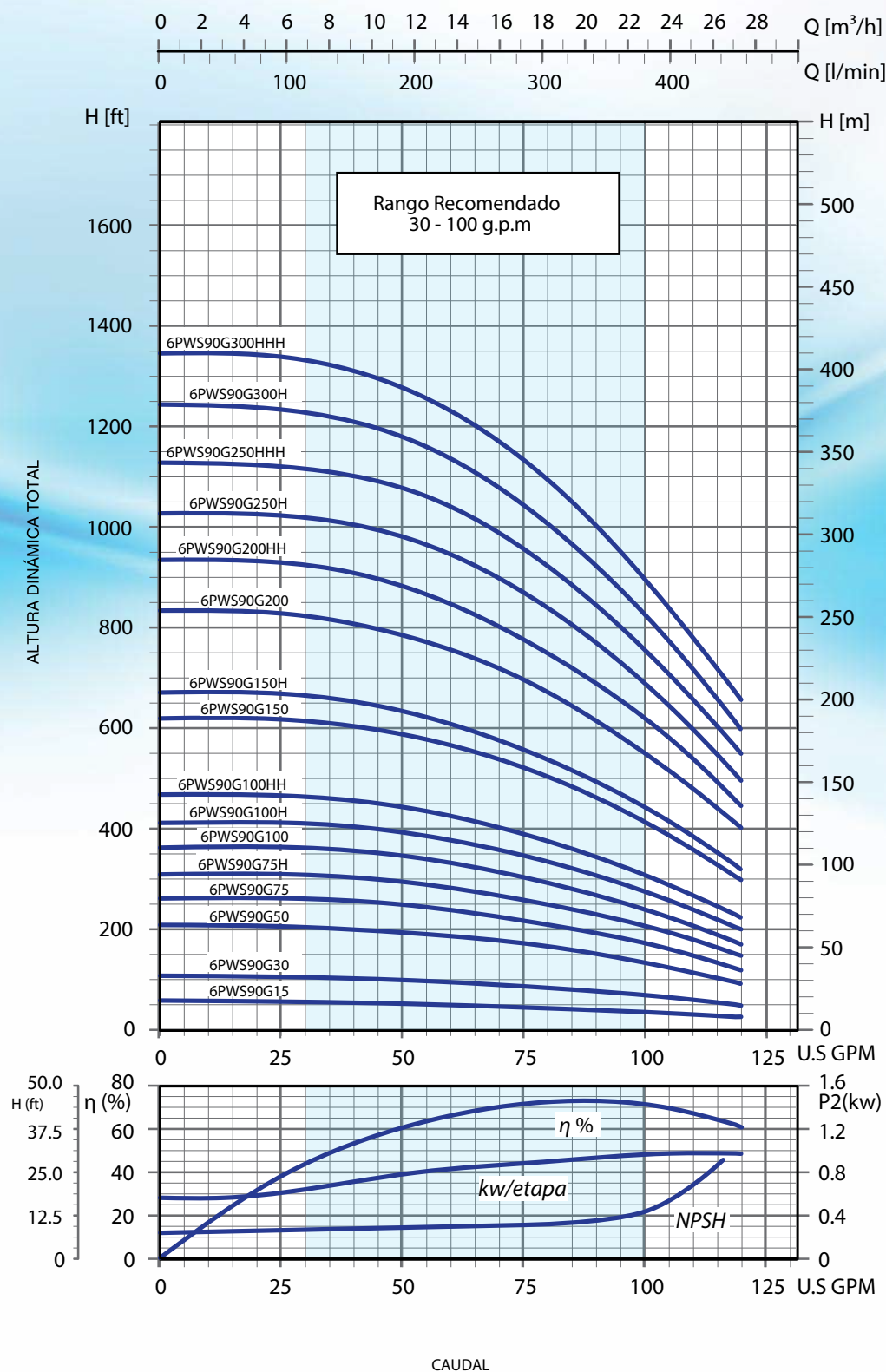

DESCARGA  
3"



# Serie 90 gpm

Tabla de Selección - 6PWS90G

MODELO	ETAPAS	MOTOR		Q = CAUDAL											
				l/min 0		94.5		189		283.5		378		472.5	
		gpm 0		25		50		75		100		125			
		KW	HP	H = ALTURA TOTAL EN METROS / ALTURA TOTAL EN PIES											
M	FT			M	FT	M	FT	M	FT	M	FT	M	FT		
6PWS90G15	1	1.1	1.5	18	60	16	51	15	50	15	48	12	40	9	30
6PWS90G30	2	2.2	3	31	103	31	101	30	100	27	90	24	80	15	50
6PWS90G50	4	3.7	5	63	205	61	201	61	199	53	173	41	135	30	98
6PWS90G75	5	5	7.5	77	253	77	251	76	250	66	215	52	170	38	125
6PWS90G75H	6	5	7.5	93	305	92	303	91	298	79	260	62	203	53	175
6PWS90G100	7	7.5	10	110	360	109	358	107	350	91	300	75	245	57	187
6PWS90G100H	8	7.5	10	125	410	124	408	122	399	107	350	84	275	61	200
6PWS90G100HH	9	7.5	10	143	470	142	465	137	450	120	395	93	305	70	230
6PWS90G150	12	11	15	189	620	188	618	182	598	159	520	124	407	91	300
6PWS90G150H	13	11	15	204	670	203	665	192	630	169	555	137	450	137	450
6PWS90G200	16	15	20	255	835	248	815	239	785	195	640	168	550	125	410
6PWS90G200HH	18	15	20	285	935	280	920	270	885	236	775	189	620	139	455
6PWS90G250H	20	18.5	25	314	1030	311	1020	299	980	265	870	210	690	154	505
6PWS90G250HHH	22	18.5	25	345	1130	340	1115	329	1080	291	955	229	750	168	550
6PWS90G300H	24	22	30	381	1250	375	1230	358	1175	320	1050	252	825	186	610
6PWS90G300HHH	26	22	30	411	1349	409	1340	389	1275	345	1130	274	900	206	675

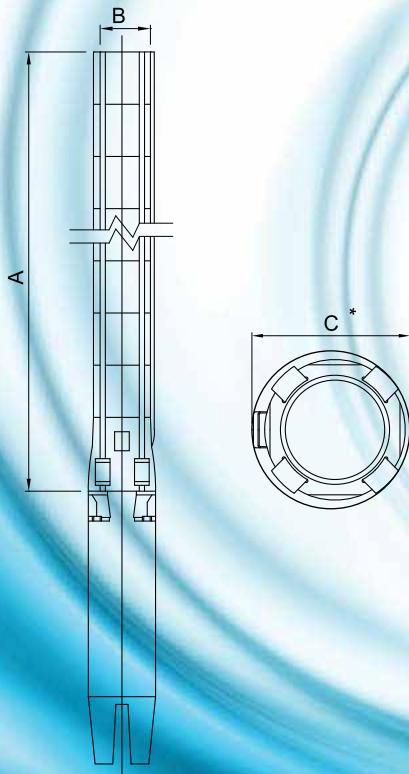

Dimensiones - 6PWS90G

MODELO	DIMENSIONES IN / MM					PESO NETO	
	A		B	C*		LBS	KG
	IN	MM	IN	IN	MM		
6PWS90G15	13.50	343	NPT 3"	5.16	131	11.05	5
6PWS90G30	15.87	403	NPT 3"	5.16	131	14.14	6.4
6PWS90G50	20.63	524	NPT 3"	5.16	131	20.55	9.3
6PWS90G75	23.03	585	NPT 3"	5.16	131	23.87	10.8
6PWS90G75H	25.39	645	NPT 3"	5.16	131	26.96	12.2
6PWS90G100	27.80	706	NPT 3"	5.59	142	30.28	13.7
6PWS90G100H	30.16	766	NPT 3"	5.59	142	33.37	15.1
6PWS90G100HH	32.56	827	NPT 3"	5.59	142	36.69	16.6
6PWS90G150	39.69	1008	NPT 3"	5.59	142	46.19	20.9
6PWS90G150H	42.09	1069	NPT 3"	5.59	142	49.50	22.4
6PWS90G200	49.21	1250	NPT 3"	5.59	142	59.01	26.7
6PWS90G200HH	53.98	1371	NPT 3"	5.59	142	65.42	29.6
6PWS90G250H	58.74	1492	NPT 3"	5.59	142	71.83	32.5
6PWS90G250HHH	63.50	1613	NPT 3"	5.59	142	78.23	35.4
6PWS90G300H	68.27	1734	NPT 3"	5.59	142	84.64	38.3
6PWS90G300HHH	73.03	1855	NPT 3"	5.59	142	91.05	41.2

C\* : Diámetro máximo de la bomba cuando es ensamblada con un cable de alimentación