

Bombas IS Industrial Service

HIERRO

Acople Universal

IU 125X100X250



Características de la bomba

Tipo de bomba	Acoplamiento	Tipo de impulsor	Temperatura máx. líquido	Sello Mecánico	Velocidad (rpm)		
Centrífuga	Universal	Cerrado Balancado ISO (G 6.3)	90 °	1 3/4" Tipo 21	3600 rpm		
Modelo	Ref.	Ø Succión	Ø Descarga	H máx. (mca) *	Q máx. (gpm) **	Etapas	Peso Kg
IU 125x100x250	1K0424	125mm	100 mm	135	1629	1	102,1

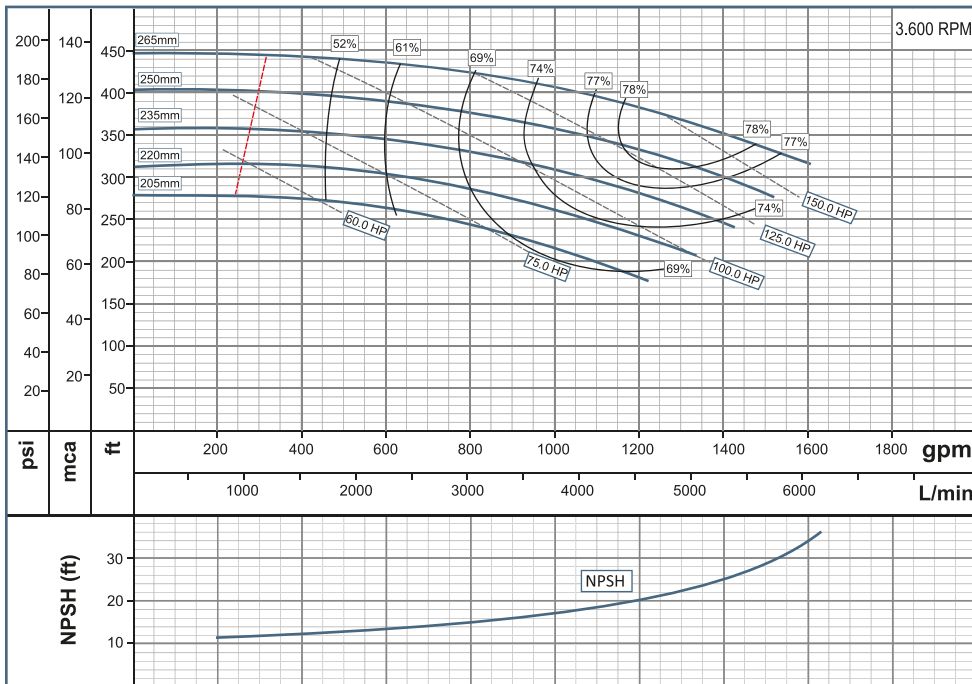

Aplicaciones

- * Suministro de Agua
- * Riego
- * Drenaje
- * Sistema de calentamiento
- * Sistema de Aire Condicionado
- * Servicio de agua
- * Agua Caliente

FLANGE		PUMP DIMENSIONS				SUPPORT DIMENSIONS					HOLES FOR		FLANGE DN1			FLANGE DN2			SHAFT END			
DN1	DN2	A	F	H1	H2	M1	M2	N1	N2	N3	W	S1	S2	Z	No	DIAM	Z	No	DIAM	U	X	Y
125	100	140	470	225	280	160	120	400	315	110	329,5	18	13	210	8	18	180	8	18	32	10	35

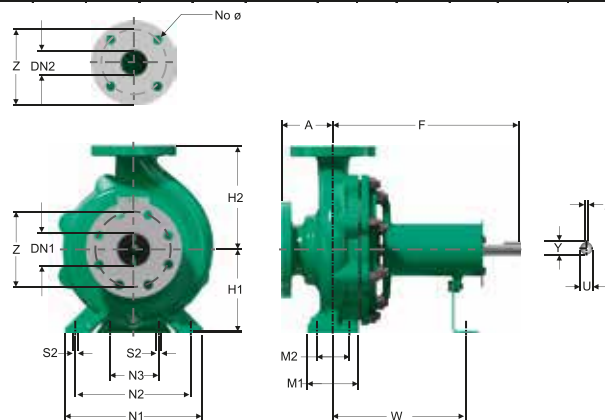

Dimensiones en milímetros

Fecha última revisión

2017-5-2